

Supercast PVC Waterstops

Centrally and externally placed, pvc waterstop profiles for use in cast in-situ concrete

USES

The Supercast range of PVC waterstops is designed to provide an integral sealing system for movement and construction joints in concrete cast in-situ. These joints typically occur in the following types of structure:

WATER RETAINING

- Reservoirs, water towers and sewage tanks
- Dams, culverts, canals and spillways
- Swimming pools
- Bunded areas surrounding liquid retaining tanks

WATER EXCLUDING

- Basements and underground car parks
- Tunnels and subways
- Abutments and retaining walls
- Roof decks and podium areas

ADVANTAGES

- Range of profiles to suit every need
- Fully continuous 4 bulbed network
- Eyeletted edge flanges for positive fixing
- Simple on-site jointing
- Full range of moulded and fabricated intersection pieces
- Complies with AS 4020

STANDARDS COMPLIANCE

Supercast PVC complies to BS 2571 - 1990, Class 3, Type E3.

DESCRIPTION

Supercast waterstops are extruded from a high grade PVC compound which has been formulated to give excellent flexibility and longevity characteristics. They are available as straight lengths and factory produced intersections or as a factory prefabricated segment of a network to minimise site jointing.

The range consists of centrally placed profiles; Supercast Hydrofoil and externally placed profiles; Supercast Rearguard S, Supercast Rearguard R.

PRINCIPLES OF WATERSTOP FUNCTION

Supercast waterstops work because of two specific aspects of their design.

a) Valve principle

Simple waterstop profiles based on dumbbells are cast into the edges of adjacent concrete panels which act as baffles. In the event of joints opening as drying shrinkage or other movement occurs, the edge bulbs of the profile act as anchors. These induce tensions across the waterstop resulting in a sealing effect at the inner faces of the edge bulbs.

b) Tortuous path principle

Profiles with more complex cross section have a much greater surface area. They present a much greater resistance and more difficult path for water to seep around the section.

The Supercast range incorporates both of these principles. The products offer a fully continuous 4 bulbed design maintaining both the valve and tortuous path principles. These principles are maintained in the transition from Rearguard profiles in floors to centrally placed profiles in walls.

SUPERCAS T HYDROFOIL SECTIONS

Centre bulb sections are used in expansion, contraction and construction joints. The centre bulb allows for movements in a structure to be accommodated whilst its hexagonal design provides a flat surface. This allows shuttering and joint fillers to fit snugly.

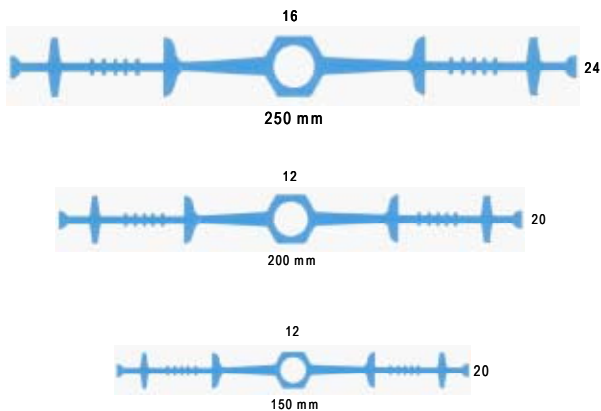

SUPERCAS T REARGUARD S

Section incorporates a flat top centre box which allows movement to be accommodated in expansion joints. The box also provides a seating to support joint fillers.

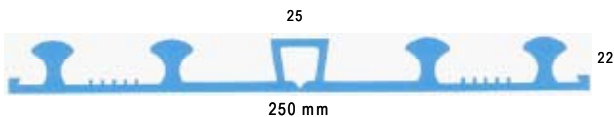

SUPERCAS T REARGUARD R

Plain web sections which are placed externally for use in contraction and construction joints. They incorporate a central fin to assist setting out shutter location.

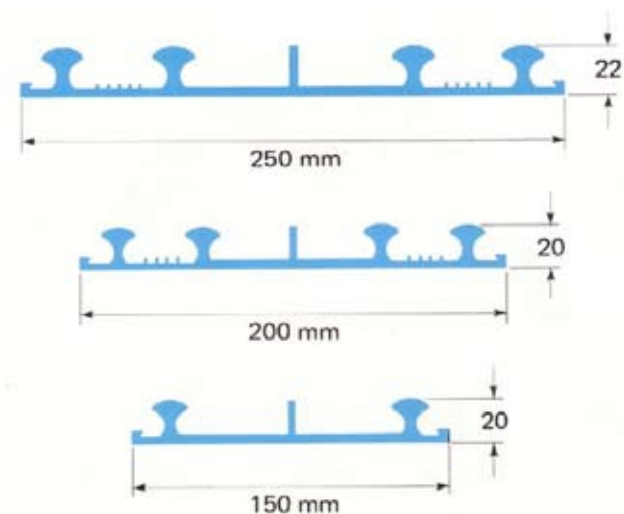

All Rearguard sections incorporate a nailing flange with a reinforced edge to provide a secure fixing that will resist tearing.

DESIGN CRITERIA

The choice of the width and thickness of waterstops is largely governed by concrete thickness, the position of the reinforcement, aggregate size and complexity of the pour.

In general the 250 mm width of waterstop is suited to wall thicknesses of 250 mm and over. For concrete less than 250 mm thick, the use of a narrower waterstop approximating to the wall thickness will be appropriate.

CENTRALLY PLACED WATERSTOP

These waterstops are positioned within the thickness of the concrete components and as a result are supported by concrete on both sides. They are therefore able to withstand water pressure from either side. This makes them suitable for use in water retaining structures. They will prevent loss of water from within the tank and will prevent ingress of ground water when the tank is drained down.

EXTERNALLY PLACED WATERSTOP

These waterstops are designed for use in basement, foundation and floor slab construction in vertical and horizontal joints in both water retaining and water excluding structures.

When used in walls, externally placed waterstops will only resist water pressure from the face to which they are fixed. When used below floor slabs, where the waterstop is supported by the building concrete or when placed in vertical situations against permanent concrete shuttering, externally placed waterstops will resist water pressure from either face.

PROPERTIES

Form:	Extruded thermoplastic sections
Colour:	Blue
Hydrostatic head:	Up to 60 m
Joint movement:	Up to 10 mm
Compound	
Typical figures:	To BS 2571, Class 3, Type G3
Tensile strength:	Minimum 16 MPa
Elongation at break:	Minimum 265%
Hardness:	Shore 'A' 70 - 90

SPECIFICATION CLAUSES

1. SUPPLIER SPECIFICATION

Where indicated on the drawings, PVC waterstops shall be Supercast Waterstops obtained from parchem. All wall / floor waterstop connections shall be made using Supercast intersections supplied by Parchem.

INSTALLATION INSTRUCTIONS

SUPERCAST HYDROFOIL

Waterstops must be installed so they are securely held in correct position while concrete is being placed. Concrete must be fully compacted around waterstops to ensure no voids or porous areas remain. Where reinforcement is present, and adequate clearance must be left to permit proper compaction.

The brass eyelets used for securing the waterstops are located outside the edge bulbs so as not to create water paths around the profile.

SUPERCAST REARGUARD

When used on ground slabs where waterstop is supported on blinding, Rearguard profiles usually require no fixing. Lay waterstop centrally over line of the joint to be formed.

Fixing to vertical shuttering is done by nailing through the outer nailing flanges leaving the head of the nail proud so that it is held in the cured concrete. This prevents the waterstop being displaced when the shuttering is struck.

Fixing to vertical shutter

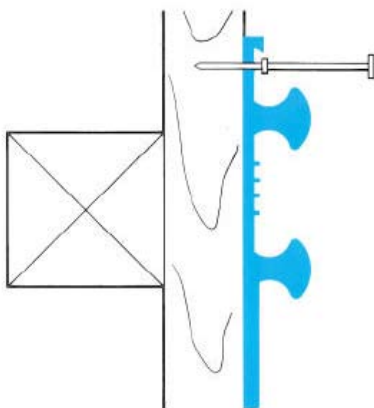

SITE JOINTING INSTRUCTIONS

Jointing of Supercast waterstops is carried out using Fosroc Heat Welding Equipment. The ends to be joined are cut square and held in alignment in a special jig. The ends are then pressed with side of a special heated blade, until an even, molten bead of PVC appears around the section. The heated blade is then removed and the molten ends pressed fully together. The PVC cools to form a strong fusion welded joint. Full instructions are available from Parchem.

Fosroc PVC heat welding equipment

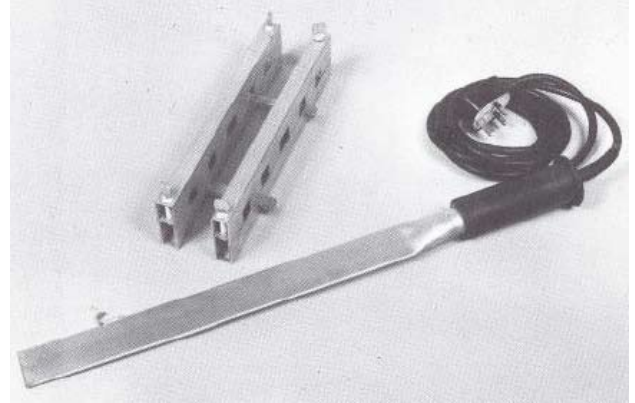

INTERSECTION PIECES

Standard intersection pieces are available for each Supercast waterstop profile. The standard on-flat intersection leg length is 230 mm from centre line. On-edge intersections have a standard 75 mm leg length.

Standards intersections available for Supercast Hydrofoil:

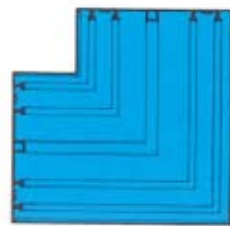

Flat mitre (M-O-F)

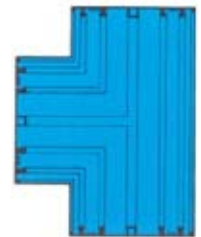

3 way on flat

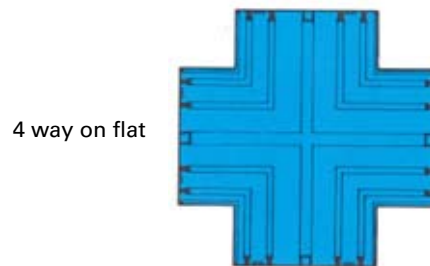

4 way on flat

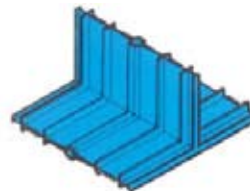

T-piece on edge (T-PCE)

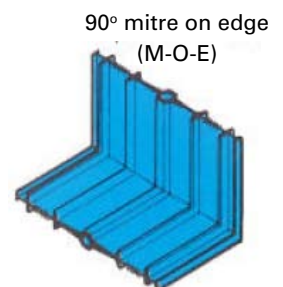

90° mitre on edge (M-O-E)

Supercast Rearguard intersections are available in the above configurations with the exception of the 90° mitre on edge and T-piece. These are replaced by:

90° mitre on edge
(M-O-E-INT)

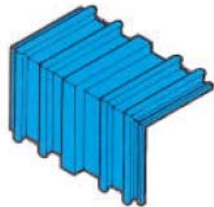
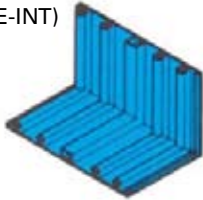

270° mitre on edge
(M-O-E-EXT)

ESTIMATING

	Section width in mm	WT/roll in kg	Minimum on flat m	radii on edge m	Roll length m
Supercast					
Hydrofoil	250	27.1	15	0.15	12
	200	27.3	14	0.15	15
	150	21.3	12	0.075	15
Rearguard R	250	29.8	10	n/a	12
	200	23.0	9	n/a	12
	150	15.2	8	n/a	12
Rearguard S	250	33.1	10	n/a	12

EQUIPMENT

Jointing jigs

150 mm Supercast Rearguard R & S

200 mm Supercast Rearguard R & S

250 mm Supercast Rearguard R & S

150 mm Supercast Hydrofoil

200 mm Supercast Hydrofoil

250 mm Supercast Hydrofoil

Heater blades

240v welding blades are available.

Warning: Ensure that heater blades are earthed by the green / yellow wire.

ADDITIONAL INFORMATION

Parchem provides a wide range of complementary products which include:

- concrete repair – cementitious and epoxy
- grouts and anchors – cementitious and epoxy
- waterproofing membranes – liquid applied, cementitious and bituminous sheet membranes
- waterstops – pvc and swellable
- joint sealants – building, civil and chemical resistant
- industrial flooring systems – cementitious and epoxy
- architectural coatings
- filler boards – swellable cork, bituminous and backing rod
- ancillary products

For further information on any of the above, please consult with your local Parchem sales office.

IMPORTANT NOTICE

A Material Safety Data Sheet (MSDS) and Technical Data Sheet (TDS) are available from the Parchem website or upon request from the nearest Parchem sales office. Read the MSDS and TDS carefully prior to use as application or performance data may change from time to time. In emergency, contact any Poisons Information Centre (phone 13 11 26 within Australia) or a doctor for advice.

PRODUCT DISCLAIMER

This Technical Data Sheet (TDS) summarises our best knowledge of the product, including how to use and apply the product based on the information available at the time. You should read this TDS carefully and consider the information in the context of how the product will be used, including in conjunction with any other product and the type of surfaces to, and the manner in which, the product will be applied. Our responsibility for products sold is subject to our standard terms and conditions of sale. Parchem does not accept any liability either directly or indirectly for any losses suffered in connection with the use or application of the product whether or not in accordance with any advice, specification, recommendation or information given by it.

*Manufactured and sold under license from Fosroc International Limited. Fosroc and the Fosroc logo are trade marks of Fosroc International Limited, used under license. *Denotes a trade mark of Fosroc International Limited.